

DV1

THE NEXT
GENERATION
SPRAY GUN



DEVILBISS
AUTOMOTIVE REFINISHING

INTRODUCING THE DV1

Professional painters understand the importance of proven spraying equipment. It is critical to have tools that not only deliver optimal performance, but also enable painters to be more successful at their trade.

The leading technicians, engineers, and designers at DeVilbiss have worked with these professional painters to create a spray gun designed specifically for painters who demand consistent, exceptional performance from their spray gun.

Introducing the DV1 – a revolutionary spray gun platform from DeVilbiss Automotive Refinishing – and a new standard in basecoat spray painting equipment.

Featuring technical innovations and atomization advancements unmatched in the industry today, the DV1 is optimized to spray the latest basecoats from the leading coatings providers. The best atomization is the right atomization for the paint being sprayed, and the DV1 is best in class at managing basecoat applications. For the painter, this means more control of their material, an improved painting experience and confidence to get the job done right, the first time, every time.

With the DV1, DeVilbiss will continue a legacy of innovation and push it further forward with groundbreaking levels of performance and efficiency. The DV1 redefines spray gun performance.

Welcome to the next generation spray gun.

Welcome to DeVilbiss.



A hand is shown holding a DeVilbiss DV1 spray gun. The gun is silver and black, with the 'DV1' logo visible on the side. The background is a solid blue color. The spray gun is positioned diagonally across the frame, with the hand gripping the handle. The lighting is dramatic, highlighting the metallic surfaces of the gun.

DV1 ADVANCEMENTS IN ATOMIZATION & PERFORMANCE

IMPROVED TRANSFER EFFICIENCY

A noticeable improvement in transfer efficiency resulting in significant savings in paint consumption to achieve a high-quality finish.

MORE EFFICIENT

Maintains superior atomization and fine particle size with reduced air consumption (CFM) and inlet pressure (PSI).

QUIETER

The DV1 sprays noticeably quieter for a more enjoyable painting experience.

LESS MOTTLING

The DV1 produces an even distribution of particles resulting in less clouding – or “mottling” – of finish material and a flawless finish.

BALANCED SPRAY PATTERN

Particle distribution is optimized symmetrically around the center line of the spray pattern to create the most even and consistent spray fan.

STABILIZED AIR DISTRIBUTION

Reduction of turbulent energy in the atomization zone resulting in a significantly more stable and consistent spray pattern.

SUPERIOR ATOMIZATION

More atomizing air velocity at the air cap, along with lower pressure, results in finer atomization and a smoother finish with better blending ability.

CONSISTENT PERFORMANCE

The DV1 offers consistent performance in a variety of environments and conditions, with all types of painters, making it easier to achieve a quality finish.

OPTIMAL COLOR MATCH

Provides the right finish, with the perfect film build, to produce the correct and uniform color every time.

EASY TO MAINTAIN

The DV1 features redesigned internal components that simplify serviceability and make the gun easy to take apart, clean and re-assemble.

IMPROVED ERGONOMICS

The DV1 employs the latest generation ergonomics and lightweight materials for an ultra-comfortable fit and feel. When spraying the DV1, painters will experience a delightfully efficient spraying experience and minimal fatigue.

The new front end of the DV1 features an improved Air and Fluid Management Architecture to create superior atomization performance and to meet the requirements of spraying the most challenging basecoats on the market today. The DV1 produces a perfectly balanced and consistent spray pattern to achieve precise color matches, seamless transitions and blends, and remarkably smooth finishes – as well as superlative metallic orientation and control.

REVOLUTIONARY AIR CAP

The new DV1-B PLUS air cap represents the next generation of atomization performance. This new HLVP air cap delivers high efficiency performance but at HVLP pressures, producing a smooth, fine finish even with the most stubborn basecoats. The DV1-B PLUS air cap is suitable for both water-based and solvent-based materials.

QUICK RELEASE AIR CAP

The hard-anodized air cap retaining ring features a quick release thread, requiring less than a full-turn rotation for fast and easy air cap removal. Painters will experience quick and easy changes of the air cap and access to the fluid tip.

INNOVATIVE FLUID TIP DESIGN

The DV1 features an overhauled fluid tip design, replicated through an expanded fluid tip size range, to tackle a broad range of coating types and flow rates in all climatic conditions. This new design dramatically increases the air velocity at the tip, while maximizing fluid suction through the gun, yielding an increased and more stable fluid flow for better color reproduction – particularly with the latest, low viscosity basecoats.

RE-DESIGNED TRIGGER

The DV1 features an innovative trigger design to remove sideways and rotary play from the trigger action, while maintaining the signature DeVilbiss fit and feel. Painters will enjoy a silent-action trigger with an exceptionally smooth, soft pull.





PRECISION DIGITAL GAUGE

The DV1 is equipped with an integrated digital gauge to provide precise inlet pressures for optimal gun performance and perfect color matching. The gauge is designed and placed in-line at eye-level for quick, easy checking – keeping it out of the way where it won't be covered by the painter's hand.

NEXT GENERATION GUN BODY

The DV1 gun body features a reduced profile and a smoother, streamlined design to create a well-balanced gun with the right feel in the painter's hand. Painters will get a sense of more control, and experience less fatigue, with a spray gun that is also easier to clean.

SIMPLIFIED AIR VALVE

The newly designed air valve cartridge features a **True-Balance** design to maximize fluid needle alignment, minimize component wear and maximize durability. Plus, this new design allows for easier removal and serviceability.

RECONFIGURED AIR ADJUSTING VALVE

The DV1 combines the air inlet and the air-adjusting valve into a single "co-axial" component and places it in an ergonomic location that is more comfortable to use. The air-adjusting valve also features 12x sensitivity for precise air control adjustments and smoother air flow through the spray gun.

DV1

BASECOAT SPRAY GUN

MODELS INCLUDE:

DV1 Basecoat Spray Gun

DV1-B PLUS HVLP Air Cap

Multiple Fluid Tips

Integrated Digital Gauge

Tool Kit: Valve Tool, Torx Driver
and Tip Wrench

ORDER NO.

704504 DV1-B PLUS Basecoat (HVLP)

AIR CAP

DV1-B PLUS

NEEDLE/NOZZLE

1.2, 1.3, 1.4

CUP TYPE

Uncupped, includes DPC adapter

Ref No.	Part No.	Description	Qty
1	-	Retaining Ring	1
2	-	Slip Ring	1
3	-	Retaining Ring Seal	1
4	704425	Retaining Ring Sub Assembly	1
5	-	Air Cap	1
6	191972	Spring Clip (Kit of 10)	1
7	See Table 1	Air Cap & Retaining Ring	1
8	See Table 2	Fluid Tip	1
9	704402	Deflector Plate	1
10+	704403	Screw (Kit of 3)	3
11	-	Sprayhead	1
12+	704401	Gasket (Kit of 2)	1
13	704400	Spray Head Kit	1
14	-	Needle Packing	1
15	-	Packing Spring	1
16	-	Packing Nut	1
17+	702731	Packing, Spring & Packing Nut Kit	1
18	-	O Ring	1
19	-	Air Valve Cage	1
20	-	Seal	2
21*	-	Seal Guide	2
22*	-	Valve Seat	1
23#	704422	Front Cage Assembly	1
24	-	Air Valve Stem	1
25#	-	Air Valve Spring	1

Ref No.	Part No.	Description	Qty
26	-	Rear Seal Housing	1
27	704423	Rear Seal Assembly	1
28+	704424	Air Valve Assembly	1
29	-	Identification Sleeve	1
30	-	Sleeve Nut	1
31	704428	Sleeve Kit	1
32	See Table 3	Fluid Needle	1
33	-	Needle Spring	1
34	-	Spring Pad	1
35#+	704405	Needle Spring Kit	1
36	704404	Fluid Adjusting Knob	1
37	-	O Ring	2
38	-	Flow Valve Body	1
39	-	Flow Valve Knob	1
40	-	Circlip	1
41	704417	Inline Flow Valve	1
42	-	Plug	1
43	-	Trigger Screw	1
44	-	Spring	1
45	-	Trigger Stud	1
46	-	Trigger	1
47	704406	Trigger, Stud, Spring & Screw Kit	1
48	-	Screw	1
49#+	-	Spreader Valve Pin	1
50	-	Spreader Valve Stem	1

Ref No.	Part No.	Description	Qty
51#+	-	O Ring	1
52	-	Valve Body	1
53#+	-	O Ring	1
54	-	Spreader Valve Adjusting Knob	1
55	704419	Spreader Knob KIT (Not For Use With Digital Gauge)	1
56	704418	Spreader Valve Assembly (Not For Use With Digital Gauge)	1
57	-	Valve Tool	1
58	-	Torx Driver	1
59	-	Tip Wrench	1
60	704429	Tool Kit	1

Gauges

61	704426	Atex Approved (EU) Digital Pressure Gauge (bar)
	704427	FM Approved (US, Canada) Digital Pressure Gauge (psi)

Service Parts

704430	Minor Service Kit	Includes Items Marked #
704431	Major Service Kit	Includes Items Marked +

TABLE 1

DV1 AIR CAP PERFORMANCE GUIDE

Part Number	Air Cap & Type	Recommended Air Inlet Pressure At Digital Gauge (with gun fully triggered)	Air Consumption	Typical Fan Pattern Size
704407	DV1-B HVLP	1.0 bar [15 psi]	400 L/min [14.1 scfm]	325 mm [12.8 in]
704408	DV1-B PLUS	1.5 bar [22 psi]	300 L/min [10.5 scfm]	330 mm [13 in]

TABLE 2

DV1 FLUID TIPS & NEEDLES

Fluid Tip			Needle	
Part Number	Fluid Tip Size	Marking	Part Number	Marking
704409	0.9	DV1-0.9 B	704416	DV1-300
704410	1.0	DV1-1.0 B		
704411	1.1	DV1-1.1 B		
704412	1.2	DV1-1.2 B		
704413	1.3	DV1-1.3 B		
704414	1.4	DV1-1.4 B		
704415	1.5	DV1-1.5 B		

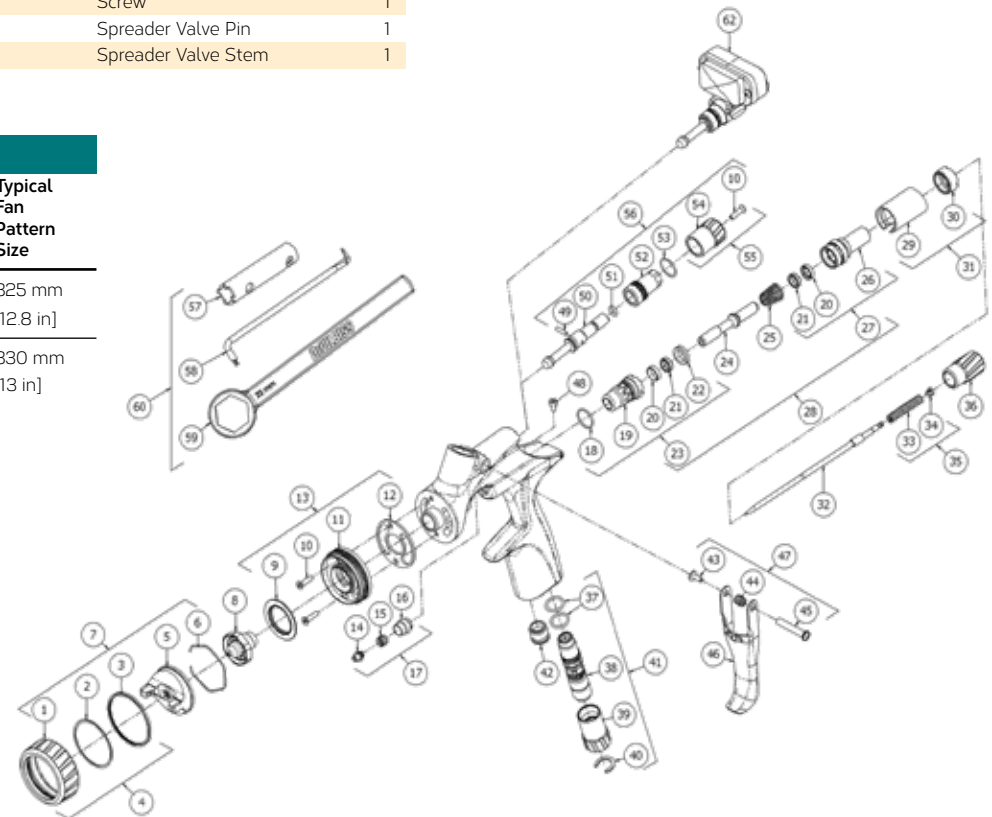

Az Ön DeVilbiss kereskedője:



Autocolor Kft.
Erdővári Ipartelep
2051 Biatorbágy
Magyarország
Tel. +36 23 311080
email: autocolor@autocolor.hu
www.autocolor.hu

DEVILBISS
AUTOMOTIVE REFINISHING

email: askus@carlisleleft.com
Customer Service: 800-445-3988
www.autorefinishdevilbiss.com